



Features:

- Constant voltage/ PWM Output (NFC regulation)
- DALI & Push dimming function (0-100%)
- AC input: 100-277VAC
- Built-in active PFC function
- Efficiency up to 83%
- Protections: Short circuit/ Over load/ Over temperature
- Cooling by free air convection
- IP20 design for indoor installation.
- Suitable for intelligent LED lighting



NFC Handheld devices



EasyNFC app



SELV IP20



Models

ELED-30-12DP2

ELED-30-24DP2

Output Specifications

Output Voltage	12V (12-13.5V adjust by NFC)	24V (24-26V adjust by NFC)
Voltage Tolerance	± 0.5%	
Output Current	2.5A	1.25A
Rated Power	3W	
Load Regulation	± 1%	

Input Specifications

Input Voltage	100-277VAC	
Frequency Range	47-63Hz	
Inrush Current	59A (Twidth=210µs 230VAC)	
Full Load Efficiency (Typ.)	87%	86.4%
AC Current (Max.)	0.8A	
Leakage Current	<0.50mA	
Power Factor	PF≥0.98@120VAC PF≥0.96@230VAC PF≥0.95@277VAC (Full loading)	

Protection

Short Circuit	Constant current mode, recovers automatically after fault condition is removed
Over Loading	≤120% constant current limiting, recovers automatically after fault condition is removed
Over Temperature	100°C± 10°C
Protection Class	I

Environment

Working Temperature	-40~+60°C (Refer to derating curve)
Working Humidity	20-95% RH, non-condensing

Safety & EMC

Storage Temperature, Humidity	-40~+80°C, 10-95% RH
Temperature Coefficient	±0.03%/°C (0-50°C)
Vibration	10-500Hz, 5G 10min./ 1 cycle, period for 60min.each along X, Y, Z axes

Safety & EMC

Safety standards	EN61347-1, EN61347-2-13, EN62493, IP20 , UL8750 (US)
Withstand voltage	I/P-O/P:3.75KVAC I/P-FG:1.88KVAC O/P-FG:0.5KVAC
Isolation resistance	I/P-O/P I/P-FG O/P-FG: 100MΩ/500VDC/25°C/70%RH
EMC Emission	Compliance to EN55015, EN61000-3-2, EN61000-3-3 (≥60% load)
EMC Immunity	Compliance to EN61000-4-2,3,4,5,6,11, EN61547

Other Specifications

Weight	0.25 Kg
Size	171.5x 54 x 20 mm
Packing	320 x 280x 215 mm (50PCS/CTN, 18 Kg/CTN))

Mechanical Specifications

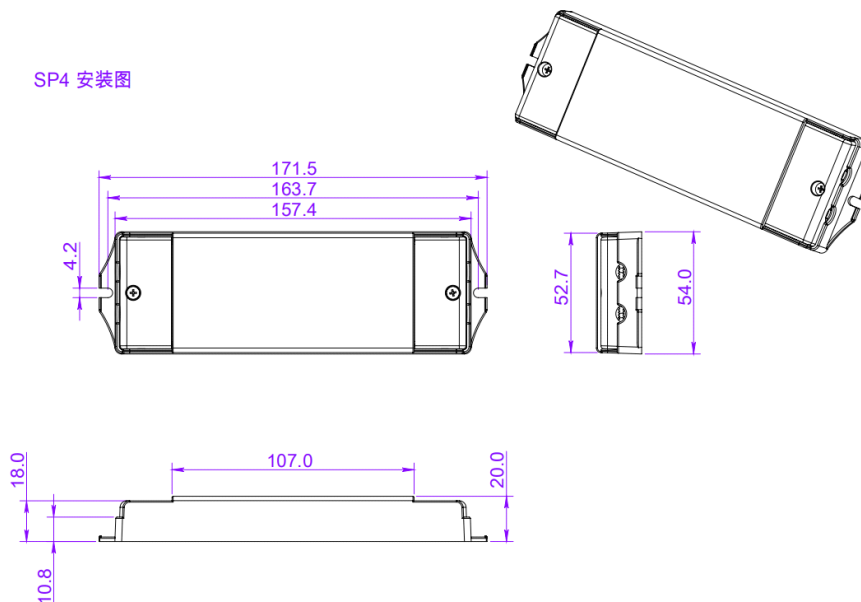

Derating Curve

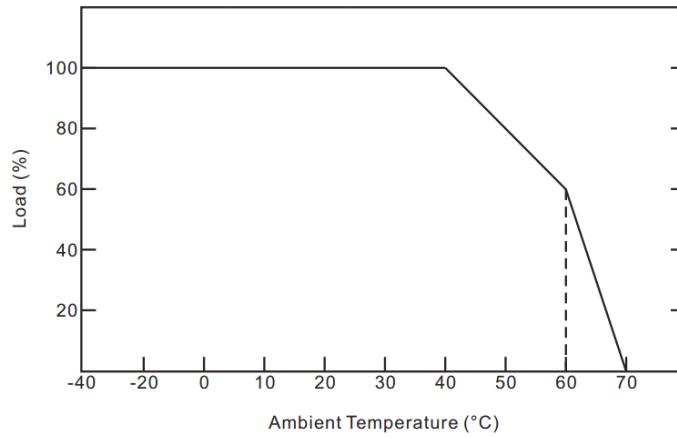

Dimming Operation

DALI Dimming Wiring Diagram1

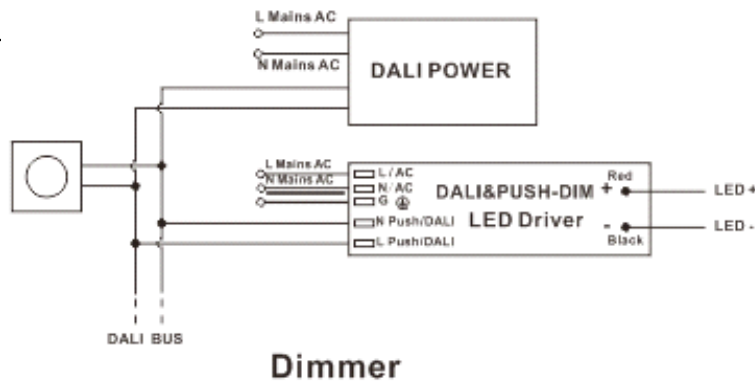

DALI Dimming Wiring Diagram2

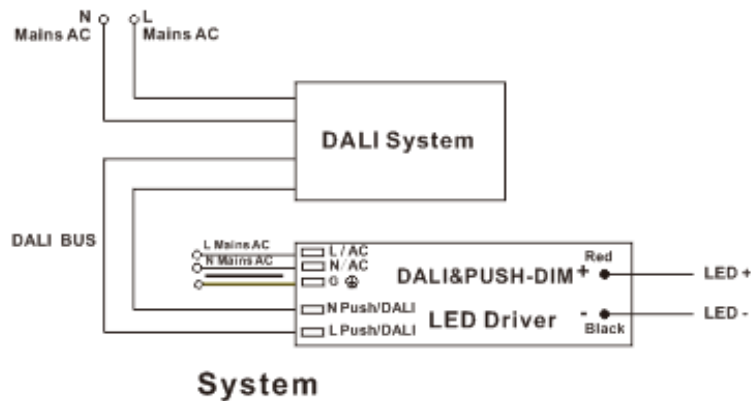

Dimming Operation

DALI Dimming Wiring Diagram 3

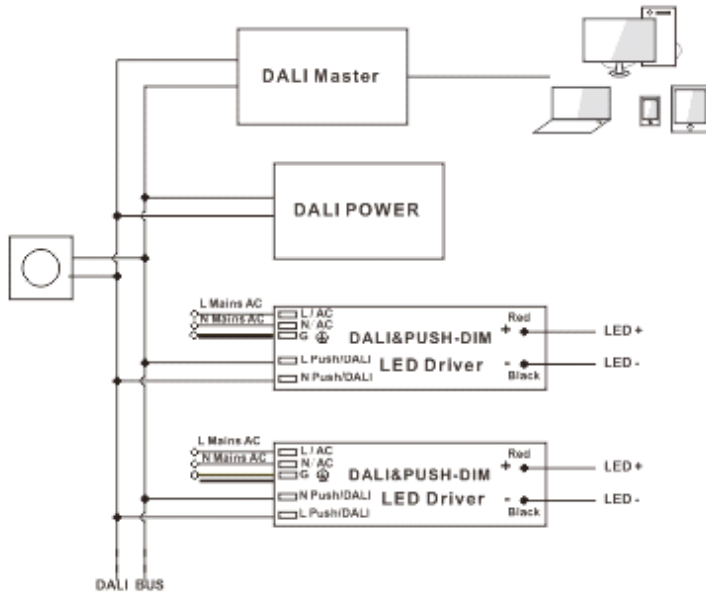

PC+DALI Master+DIMMER

Push-Dimming Wiring Diagram 1

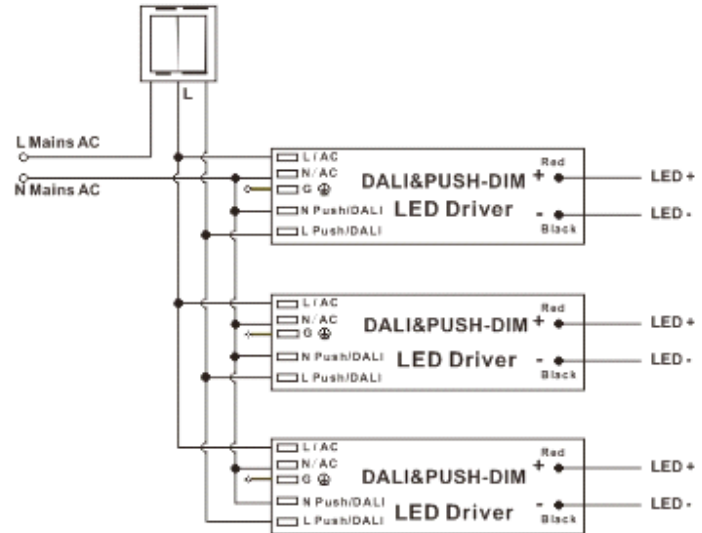

Dimmer (with ON/OFF function)

Push-Dimming Wiring Diagram 2

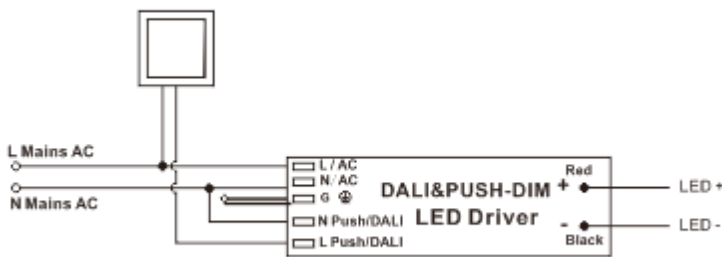

Dimmer

※Note: For DALI Dimming Wiring Diagram 3, please noted that only one DALI power is need in the DALI bus, so no extra DALI power is needed if the Master or Dimmer already includes the DALI Power.