

## Features:

- Constant voltage
- 3 in 1 dimming function (0/1-10Vdc or 10v PWM signal or resistance)
- AC input: 100-265VAC
- Built-in active PFC function
- High efficiency up to 82%
- Protections: Short circuit/Over current/Over loading
- Cooling by free air convection
- Suitable for LED lighting and moving signs



## Models

### ELED-20-12V

### ELED-20-24V

## Output Specifications

	ELED-20-12V	ELED-20-24V
Output Voltage	12V	24V
Voltage Tolerance	± 0.5%	
Output Current	1.67A	0.83A
Rated Power	20W	

## Input Specifications

Input Voltage	100-265VAC	
Frequency Range	47-63Hz	
Inrush Current	22.4A (Twidth=140µs 230VAC)	
Full Load Efficiency (Typ.)	80%	82%
AC Current (Max.)	0.23A	
Leakage Current	<0.50mA	
Power Factor	PF>0.95/120VAC PF>0.95/230VAC PF>0.95/265VAC (Full Loading)	

## Protection

Short Circuit	Hicup mode, recovers automatically after fault condition is removed
Over Loading	≤120%
Over Current	≤1.2*Iout

## Environment

Working Temperature	-40~+60°C (Refer to derating curve)
Working Humidity	20-90% RH, non-condensing
Storage Temperature, Humidity	-40~+80°C, 10-95% RH
Temperature Coefficient	±0.03%/°C (0-50°C)

### Environment

Vibration 10-500Hz 2G 12min./ 1 cycle, period for 72min. each along X, Y, Z axes

### Safety & EMC

Safety standards EN61347-1, EN61347-2-13

Withstand voltage I/P-O/P:3.75KVAC

Isolation resistance I/P-O/P:100MΩ/500VDC/25°C/70%RH

EMC Emission Compliance to EN55015, EN61000-3-2

EMC Immunity Compliance to EN61000-4-2,3,4,5,6,11, EN61547, light industry Level Criteria A

### Other Specifications

Weight 0.17 Kg

Size 140 x 45 x 27 mm

Packing 320 x 280 x 215 mm (50PCS/CTN)

### Mechanical Specifications

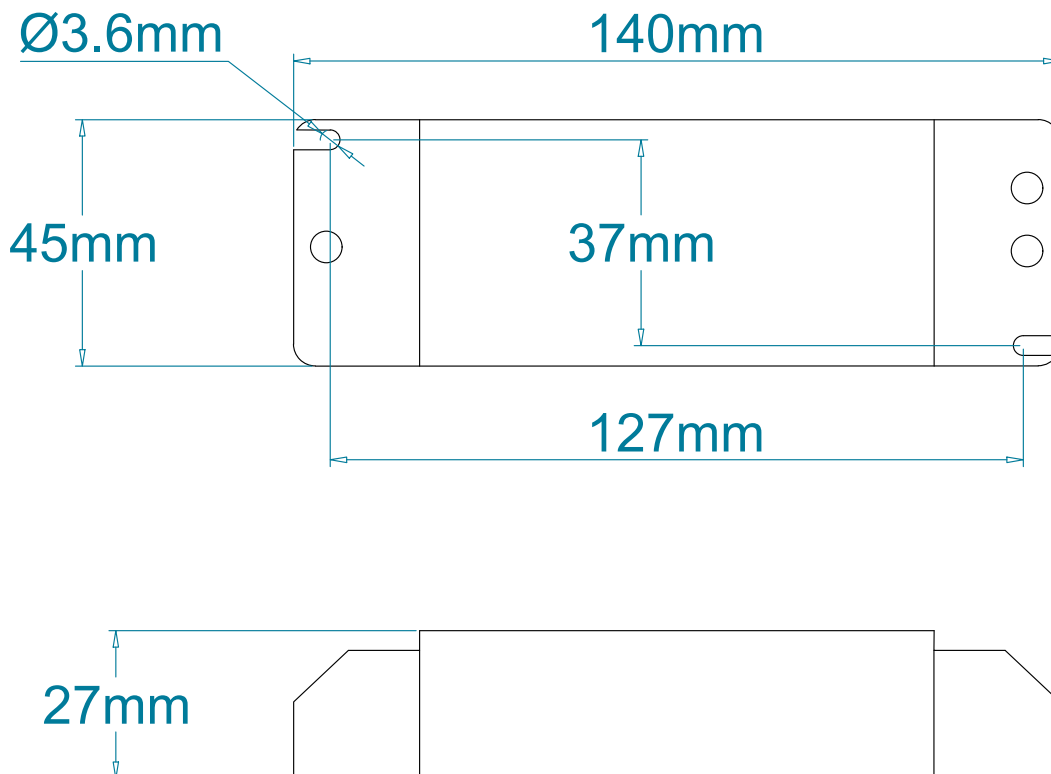

## Derating Curve

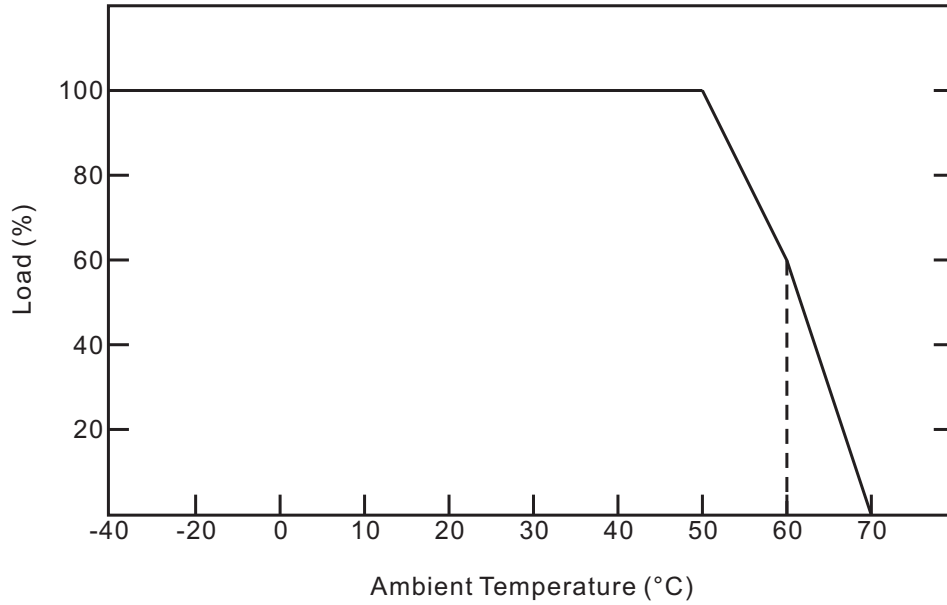

## Connection Drawing

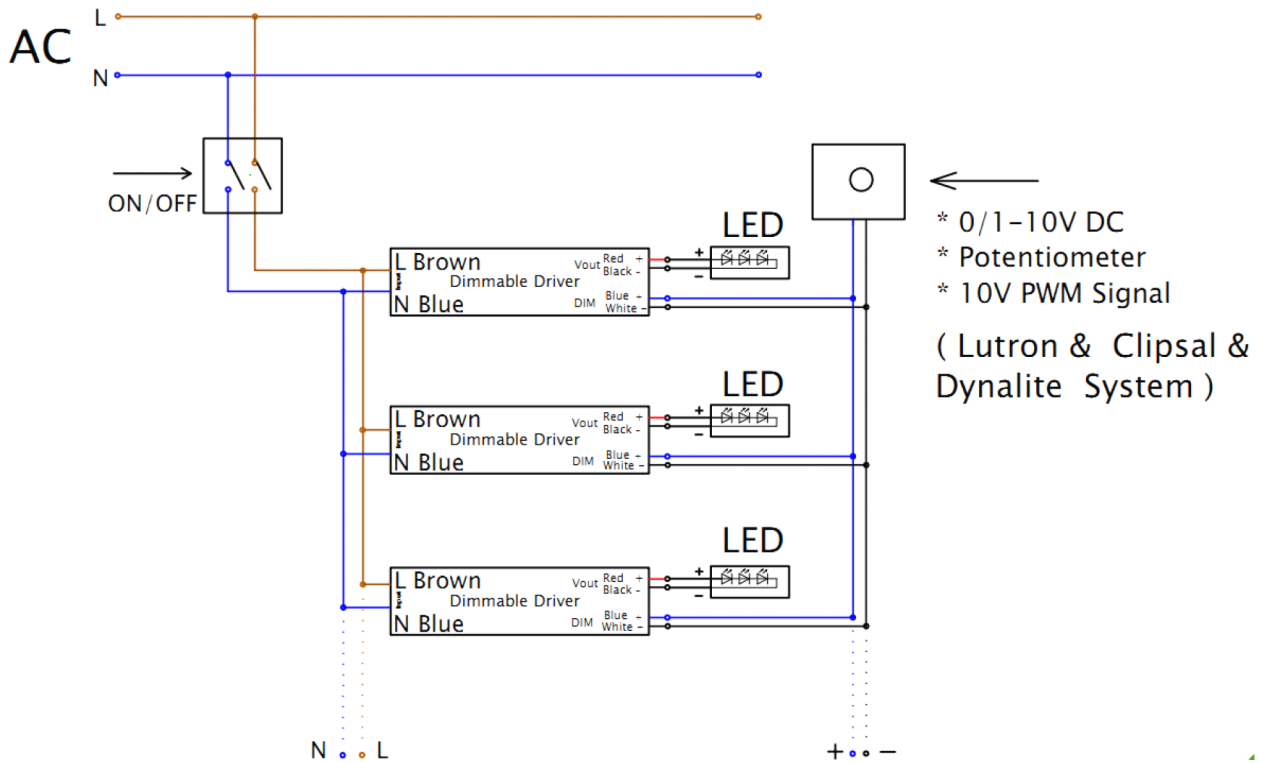

## Connection Drawing

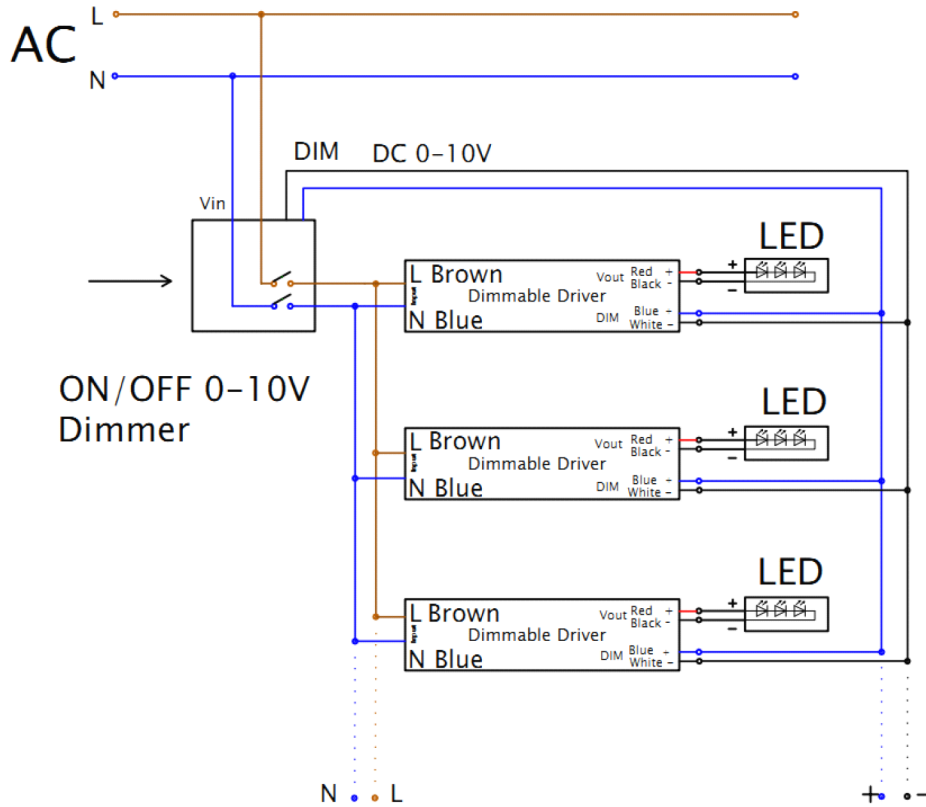

## Dimming Operation

※Reference resistance value: (Typical)

Resistance value	Single driver	0Ω	10KΩ	20KΩ	30KΩ	40KΩ	50KΩ	60KΩ	70KΩ	80KΩ	90KΩ	100KΩ	OPEN
	Multiple drivers	0Ω/N	10KΩ/N	20KΩ/N	30KΩ/N	40KΩ/N	50KΩ/N	60KΩ/N	70KΩ/N	80KΩ/N	90KΩ/N	100KΩ/N	—
Percentage of luminous		0%	10%	20%	30%	40%	50%	60%	70%	80%	90%	100%	100%

※1-10/0-10V dimmable function :(Typical)

Dimming value	0V	1V	2V	3V	4V	5V	6V	7V	8V	9V	10V	OPEN
Percentage of luminous	0%	10%	20%	30%	40%	50%	60%	70%	80%	90%	100%	100%

※10V PWM signal: (Typical): Frequency range:100Hz-3KHZ

Duty value	0%	10%	20%	30%	40%	50%	60%	70%	80%	90%	100%	OPEN
Percentage of luminous	0%	10%	20%	30%	40%	50%	60%	70%	80%	90%	100%	100%